

Operating Instructions · April 2008



million
in one

SITRANS LVL200S
RELAY (DPDT)

SIEMENS

Content

1	About this document	
1.1	Function	4
1.2	Target group	4
1.3	Symbolism used	4
2	For your safety	
2.1	Authorised personnel	5
2.2	Appropriate use	5
2.3	Warning about misuse	5
2.4	General safety instructions	5
2.5	Safety approval markings and safety tips	6
2.6	CE conformity	6
2.7	SIL conformity	6
2.8	Safety instructions for Ex areas	6
3	Product description	
3.1	Configuration	7
3.2	Principle of operation	8
3.3	Operation	9
3.4	Storage and transport	9
4	Mounting	
4.1	General instructions	11
4.2	Mounting instructions	14
5	Connecting to power supply	
5.1	Preparing the connection	16
5.2	Connection procedure	16
5.3	Wiring plan, single chamber housing	17
6	Set up	
6.1	In general	19
6.2	Adjustment elements	19
6.3	Functional chart	20
7	Maintenance and fault rectification	
7.1	Maintenance	22
7.2	Remove interferences	22
7.3	Exchange electronics	23
7.4	Instrument repair	23
8	Dismounting	
8.1	Dismounting steps	24

8.2 Disposal 24

9 Supplement

9.1 Technical data. 25

9.2 Dimensions 33

Supplementary documentation



Information:

Supplementary documents appropriate to the ordered version come with the delivery. You can find them listed in chapter "*Product description*".

Instructions manuals for accessories and replacement parts



Tip:

To ensure reliable setup and operation of your SITRANS LVL200S, we offer accessories and replacement parts. The associated documents are:

- 33997 - Electronics module SITRANS LVL200

1 About this document

1.1 Function

This operating instructions manual provides all the information you need for mounting, connection and setup as well as important instructions for maintenance and fault rectification. Please read this information before putting the instrument into operation and keep this manual accessible in the immediate vicinity of the device.

1.2 Target group

This operating instructions manual is directed to trained personnel. The contents of this manual should be made available to these personnel and put into practice by them.

1.3 Symbolism used



Information, tip, note

This symbol indicates helpful additional information.



Caution: If this warning is ignored, faults or malfunctions can result.

Warning: If this warning is ignored, injury to persons and/or serious damage to the instrument can result.

Danger: If this warning is ignored, serious injury to persons and/or destruction of the instrument can result.



Ex applications

This symbol indicates special instructions for Ex applications.



List

The dot set in front indicates a list with no implied sequence.



Action

This arrow indicates a single action.



Sequence

Numbers set in front indicate successive steps in a procedure.

2 For your safety

2.1 Authorised personnel

All operations described in this operating instructions manual must be carried out only by trained specialist personnel authorised by the plant operator.

During work on and with the device the required personal protection equipment must always be worn.

2.2 Appropriate use

SITRANS LVL200S is a sensor for level detection.

You can find detailed information on the application range in chapter "*Product description*".

Operational reliability is ensured only if the instrument is properly used according to the specifications in the operating instructions manual as well as possible supplementary instructions.

For safety and warranty reasons, any invasive work on the device beyond that described in the operating instructions manual may be carried out only by personnel authorised by the manufacturer. Arbitrary conversions or modifications are explicitly forbidden.

2.3 Warning about misuse

Inappropriate or incorrect use of the instrument can give rise to application-specific hazards, e.g. vessel overfill or damage to system components through incorrect mounting or adjustment.

2.4 General safety instructions

This is a high-tech instrument requiring the strict observance of standard regulations and guidelines. The user must take note of the safety instructions in this operating instructions manual, the country-specific installation standards as well as all prevailing safety regulations and accident prevention rules.

The instrument must only be operated in a technically flawless and reliable condition. The operator is responsible for trouble-free operation of the instrument.

During the entire duration of use, the user is obliged to determine the compliance of the required occupational safety measures with the current valid rules and regulations and also take note of new regulations.

2.5 Safety approval markings and safety tips

The safety approval markings and safety tips on the device must be observed.

2.6 CE conformity

SITRANS LVL200S is in CE conformity with EMC (89/336/ EWG), fulfils NAMUR recommendation NE 21 and is in CE conformity with LVD (73/23/EG).

Conformity has been judged according to the following standards:

- EMC:
 - Emission EN 61326/A1: 1998 (class B)
 - Susceptibility EN 61326: 1997/A1:1998
- LVD: EN 61010-1: 1993

2.7 SIL conformity

SITRANS LVL200S fulfills the requirements to functional safety according to IEC 61508/IEC 61511. You find further information in the Safety Manual "*SITRANS LVL200*".

2.8 Safety instructions for Ex areas

Please note the Ex-specific safety information for installation and operation in Ex areas. These safety instructions are part of the operating instructions manual and come with the Ex-approved instruments.

3 Product description

3.1 Configuration

Scope of delivery

The scope of delivery encompasses:

- SITRANS LVL200S point level sensor
- Documentation
 - this operating instructions manual
 - Safety Manual "*Functional safety according to IEC 61508 or IEC 61511 (SIL)*"
 - Ex-specific "*Safety instructions*" (with Ex-versions)
 - if necessary, further certificates

Components

SITRANS LVL200S consists of the following components:

- Housing cover
- Housing with electronics
- process fitting with tuning fork

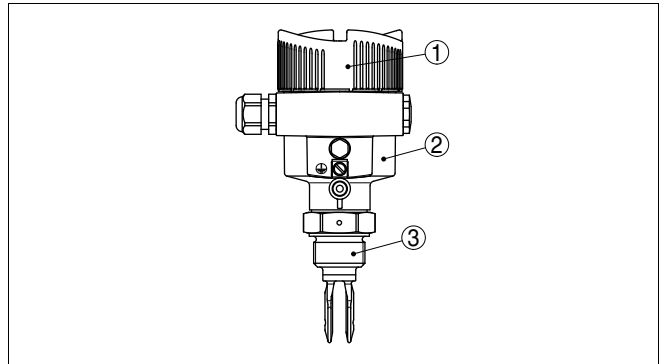

Fig. 1: SITRANS LVL200S

- 1 Housing cover
- 2 Housing with electronics
- 3 Process fitting

Type label

The type label contains the most important data for identification and use of the instrument:

- Article number
- Serial number
- Technical data
- Article numbers, documentation

3.2 Principle of operation

Area of application	<p>SITRANS LVL200S is a point level sensor with tuning fork for level detection.</p> <p>It is designed for industrial use in all areas of process technology and can be used in liquids.</p> <p>Typical applications are overflow and dry run protection. With a tuning fork of only 40 mm length, SITRANS LVL200S can be also mounted, e.g. in pipelines from DN 25. The small tuning fork allows use in vessels, tanks and pipes. Thanks to its simple and robust measuring system, SITRANS LVL200S is virtually unaffected by the chemical and physical properties of the liquid.</p> <p>It functions even under difficult conditions such as turbulence, air bubbles, foam generation, buildup, strong external vibration or changing products.</p> <p>Fault monitoring</p> <p>The electronics module of SITRANS LVL200S continuously monitors via frequency evaluation the following criteria:</p> <ul style="list-style-type: none">● Strong corrosion or damage on the tuning fork● loss of vibration● Line break to the piezo drive <p>If a malfunction is detected or in case of power failure, the electronics takes on a defined switching condition, i.e. the relay deenergises (safe condition).</p>
Functional principle	<p>The tuning fork is piezoelectrically energised and vibrates at its mechanical resonance frequency of approx. 1200 Hz. The piezos are fixed mechanically and are hence not subject to temperature shock limitations. The frequency changes when the tuning fork is covered by the medium. This change is detected by the integrated oscillator and converted into a switching command.</p>
Supply voltage	<p>SITRANS LVL200S is a compact instrument, i.e. it can be operated without external evaluation system. The integrated electronics evaluates the level signal and outputs a switching signal. With this switching signal, a connected device can be operated directly (e.g. a warning system, a PLC, a pump etc.).</p> <p>Data for power supply are specified in chapter "<i>Technical data</i>".</p>

3.3 Operation

With the factory setting, products with a density $> 0.07 \text{ g/cm}^3$ (0.025 lbs/in^3) can be measured. The instrument can be adapted if products with lower density should be measured.

On the electronics module you will find the following indicating and adjustment elements:

- Signal lamp for indication of the switching condition (green/red)
- DIL switch for sensitivity adjustment
- Mode adjustment for selection of the switching condition (A/B)

3.4 Storage and transport

Packaging

Your instrument was protected by packaging during transport. Its capacity to handle normal loads during transport is assured by a test according to DIN EN 24180.

The packaging of standard instruments consists of environment-friendly, recyclable cardboard. In addition, the sensor is provided with a protective cover of ABS. For special versions PE foam or PE foil is also used. Dispose of the packaging material via specialised recycling companies.

Transport

Transport must be carried out under consideration of the notes on the transport packaging. Nonobservance of these instructions can cause damage to the device.

Transport inspection

The delivery must be checked for completeness and possible transit damage immediately at receipt. Ascertained transit damage or concealed defects must be appropriately dealt with.

Storage

Up to the time of installation, the packages must be left closed and stored according to the orientation and storage markings on the outside.

Unless otherwise indicated, the packages must be stored only under the following conditions:

- Not in the open
- Dry and dust free
- Not exposed to corrosive media
- Protected against solar radiation
- Avoiding mechanical shock and vibration

Storage and transport temperature

- Storage and transport temperature see "*Supplement - Technical data - Ambient conditions*"
- Relative humidity 20 ... 85 %

4 Mounting

4.1 General instructions

Switching point

In general, SITRANS LVL200S can be installed in any position. The instrument simply has to be mounted in such a way that the tuning fork is at the height of the desired switching point.

The tuning fork has lateral markings (notches) that indicate the switching point with vertical mounting. The switching point refers to water with the basic setting of the sensitivity switch $\geq 0.7 \text{ g/cm}^3$ (0.025 lbs/in^3). When mounting SITRANS LVL200S, make sure that this marking is at the height of the requested switching point. Keep in mind that the switching point of the instrument is shifted if the medium has a density other than water - water 1 g/cm^3 (0.036 lbs/in^3). For products $< 0.7 \text{ g/cm}^3$ (0.025 lbs/in^3) and $> 0.5 \text{ g/cm}^3$ (0.018 lbs/in^3) the density switch must be set to $\geq 0.5 \text{ g/cm}^3$.

Keep in mind that foams with a density $> 0.45 \text{ g/cm}^3$ (0.016 lbs/in^3) are detected by the sensor. This can cause faulty switchings particularly when used as dry run protection system.

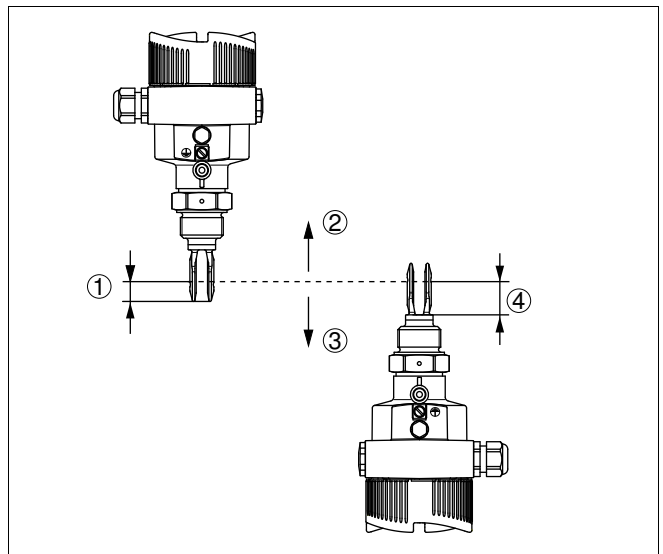

Fig. 2: Vertical mounting

- 1 Switching point approx. 13 mm (0.51 in)
- 2 Switching point with lower density
- 3 Switching point with higher density
- 4 Switching point approx. 27 mm (1.06 in)

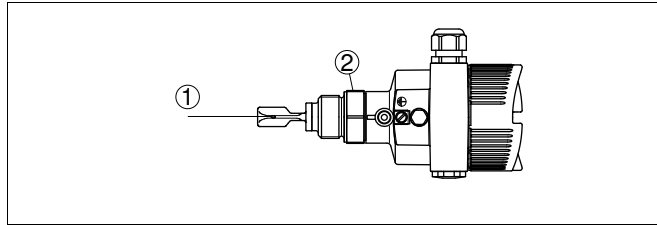

Fig. 3: Horizontal mounting
1 Switching point

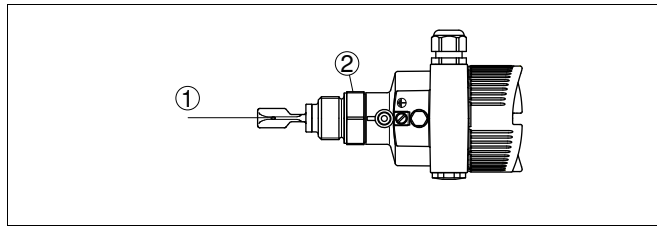

Fig. 4: Horizontal installation (recommended installation position, especially for adhesive products)
1 Switching point
2 Marking with screwed version on top, with flange versions directed to the flange holes

With flange versions, the fork is directed as follows to the flange holes.

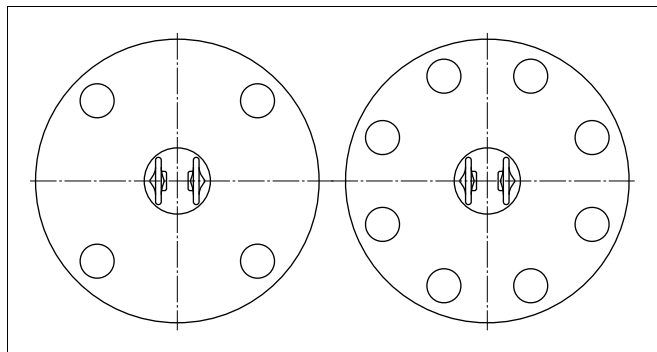

Fig. 5: Fork position with flange versions

Moisture

Use the recommended cables (see chapter "Connecting to power supply") and tighten the cable gland.

You can give your SITRANS LVL200S additional protection against moisture penetration by leading the connection cable downward in front of the cable entry. Rain and condensation water can thus drain off. This applies mainly to mounting outdoors, in areas where moisture is expected (e.g. by cleaning processes) or on cooled or heated vessels.

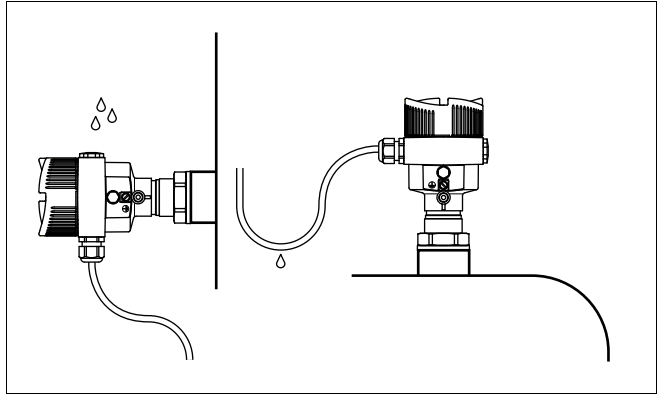

Fig. 6: Measures against moisture penetration

Transport

Do not hold SITRANS LVL200S on the tuning fork. Particularly with flange or tube versions, the tuning fork can be damaged just by the weight of the instrument. Transport coated instruments very carefully and avoid touching the tuning fork.

Remove the protective cover just before mounting.

Pressure/Vacuum

The process fitting must be sealed if there is gauge or low pressure in the vessel. Before use, check if the seal material is resistant against the measured product and the process temperature.

The max. permissible pressure is specified in chapter "Technical data" or on the type label of the sensor.

Handling

The vibrating level switch is a measuring instrument and must be treated accordingly. Bending the vibrating element will destroy the instrument.



Warning:

The housing must not be used to screw the instrument in! Applying tightening force can damage internal parts of the housing.

Use the hexagon above the thread for screwing in.

4.2 Mounting instructions

Welded socket

SITRANS LVL200S has a defined thread starting point. This means that every SITRANS LVL200S is in the same fork position after being screwed in. Remove therefore the supplied seal from the thread of SITRANS LVL200S. This seal is not required when using a welded socket with O-ring in front.

Keep in mind that this welded socket is not suitable for coated instrument versions.

Screw SITRANS LVL200S completely into the welded socket. The later position can be determined already before welding. Mark the appropriate position of the welded socket. Before welding, unscrew SITRANS LVL200S and remove the rubber ring from the welded socket. The welded socket has a marking (notch). Weld the socket with the notch facing upward, or in case of pipelines, aligned with the direction of flow.

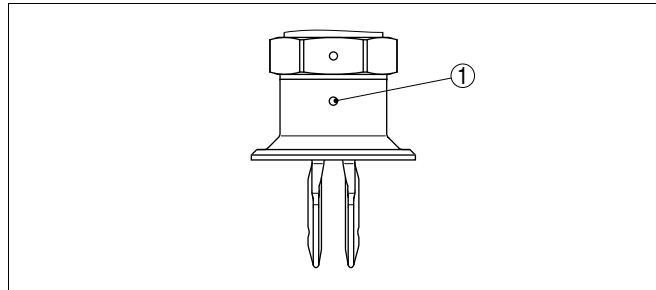

Fig. 7: Marking on the welded socket
1 Marking

Adhesive products

In case of horizontal mounting in adhesive and viscous products, the surfaces of the tuning fork should be vertical in order to reduce buildup on the tuning fork. On the screwed version you will find a marking on the hexagon. With this, you can check the position of the tuning fork when screwing it in. When the hexagon touches the seal, the thread can still be turned by approx. half a turn. This is sufficient to reach the recommended installation position.

With flange versions, the fork is directed to the flange holes.

When used in adhesive and viscous products, the tuning fork should protrude into the vessel to avoid buildup. For that reason, sockets for flanges and mounting bosses should be avoided when mounting horizontally.

Inflowing medium

If SITRANS LVL200S is mounted in the filling stream, unwanted false measurement signals can be generated. For this reason, mount SITRANS LVL200S at a position in the vessel where no disturbances, e.g. from filling openings, agitators, etc., can occur.

Flows

To minimise flow resistance caused by the tuning fork, SITRANS LVL200S should be mounted in such a way that the surfaces of the blades are parallel to the product movement.

5 Connecting to power supply

5.1 Preparing the connection

Note safety instructions

Always keep in mind the following safety instructions:

- Connect only in the complete absence of line voltage

Take note of safety instructions for Ex applications



In hazardous areas you should take note of the appropriate regulations, conformity and type approval certificates of the sensors and power supply units.

Select power supply

Connect the power supply according to the following diagrams. Oscillator with relay output is designed in protection class 1. To maintain this protection class, it is absolutely necessary that the ground conductor be connected to the internal ground terminal. Take note of the general installation regulations. As a rule, connect SITRANS LVL200S to vessel ground (PA), or in case of plastic vessels, to the next ground potential. On the side of the housing there is a ground terminal between the cable entries. This connection serves to drain off electrostatic charges. In Ex applications, the installation regulations for hazardous areas must be given priority.

Data for power supply are specified in chapter "*Technical data*".

Selecting connection cable

SITRANS LVL200S is connected with standard cable with round cross section. An outer cable diameter of 5 ... 9 mm (0.2 ... 0.35 in) ensures the seal effect of the cable gland.

If cable with a different diameter or wire cross section is used, exchange the seal or use an appropriate cable connection.



In hazardous areas, only use approved cable connections for SITRANS LVL200S.

Select connection cable for Ex applications



Take note of the corresponding installation regulations for Ex applications.

5.2 Connection procedure



With Ex instruments, the housing cover may only be opened if there is no explosive atmosphere present.

Proceed as follows:

- 1 Unscrew the housing cover
- 2 Loosen compression nut of the cable entry
- 3 Remove approx. 10 cm (4 in) of the cable mantle, strip approx. 1 cm (0.4 in) insulation from the ends of the individual wires
- 4 Insert the cable through the cable gland into the sensor
- 5 Open the terminals with a screwdriver
- 6 Insert the wire ends into the open terminals according to the wiring plan
- 7 Tighten the terminals with a screwdriver
- 8 Check the hold of the wires in the terminals by lightly pulling on them
- 9 Tighten the compression nut of the cable entry. The seal ring must completely encircle the cable
- 10 Screw the housing cover on

The electrical connection is finished.

5.3 Wiring plan, single chamber housing



The following illustrations apply to the non-Ex as well as to the EEx-d version.

Electronics and connection compartment

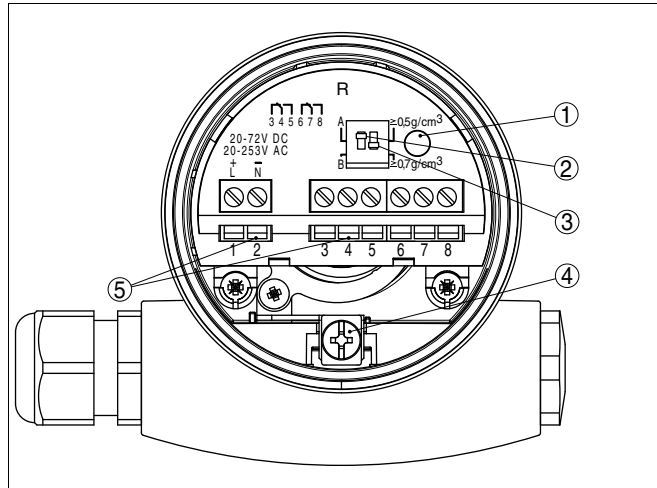

Fig. 8: Electronics and connection compartment, single chamber housing

- 1 Control lamp
- 2 DIL switch for mode adjustment
- 3 DIL switch for switching point adaptation
- 4 Ground terminal
- 5 Connection terminals

Wiring plan

We recommend connecting SITRANS LVL200S in such a way that the switching circuit is open when there is a level signal, line break or failure (safe condition).

The relays are always shown in non-operative condition.

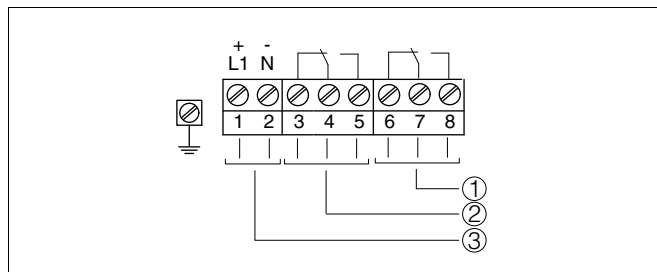

Fig. 9: Wiring plan, single chamber housing

- 1 Relay output
- 2 Relay output
- 3 Voltage supply

6 Set up

6.1 In general

The numbers in brackets refer to the following illustrations.

Function/Configuration

In the basic setting, products with a density $> 0.7 \text{ g/cm}^3$ (0.025 lbs/in^3) can be detected. For products with lower density, you have to set the switch to $> 0.5 \text{ g/cm}^3$ (0.018 lbs/in^3).

On the electronics module you will find the following indicating and adjustment elements:

- Control lamp for indication of the switching condition (1)
- DIL switch for mode adjustment - A/B (2)
- DIL switch for sensitivity adjustment (3)



Note:

For test purposes, immerse the tuning fork of SITRANS LVL200S always in liquids. Do not test the function of SITRANS LVL200S with the hand. This can damage the sensor.

6.2 Adjustment elements

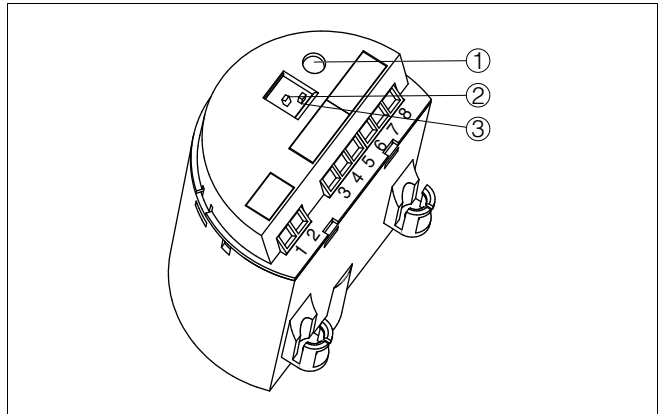

Fig. 10: Oscillator SWE60R - Relay output

- 1 Signal lamp (LED)
- 2 DIL switch for mode adjustment
- 3 DIL switch for sensitivity adjustment

Signal lamp (1)

Control lamp for indication of the switching status.

- green = relay energized
- red = relay deenergized
- red (flashing) = failure

Mode adjustment (2)

With the mode adjustment (A/B) you can change the switching condition of the relay. You can set the required mode according to the "Function chart" (A - max. detection or overflow protection, B - min. detection or dry run protection).









Sensitivity adjustment (3)







With this DIL switch (3) you can set the switching point to liquids having a density between 0.5 and 0.7 g/cm³ (0.018 and 0.025 lbs/in³). With the basic setting, liquids with a density of > 0.7 g/cm³ (0.025 lbs/in³) can be detected. In liquids with lower density, you must set the switch to > 0.5 g/cm³ (0.018 lbs/in³). The specifications for the position of the switching point relate to water - density value 1 g/cm³ (0.036 lbs/in³). In products with a different density, the switching point will shift in the direction of the housing or tuning fork end depending on the density and type of installation.

Keep in mind that foams with a density > 0.45 g/cm³ (0.016 lbs/in³) are detected by the sensor. This can cause faulty switchings particularly when used as dry run protection system.

6.3 Functional chart

The following chart provides an overview of the switching conditions depending on the adjusted mode and level.

	Level	Switching status	Control lamp
Mode A Overflow protection		 Relay energized	 Green
Mode A Overflow protection		 Relay deenergized	 Red
Mode B Dry run protection		 Relay energized	 Green

	Level	Switching status	Control lamp
Mode B Dry run protection		 Relay deenergized	 Red
Failure of the supply voltage (mode A/B)	any	 Relay deenergized	 off
Failure	any	 Relay deenergized	 flashes red

7 Maintenance and fault rectification

7.1 Maintenance

When used in the correct way, no special maintenance is required in normal operation.

7.2 Remove interferences

Reaction when malfunctions occur	The operator of the system is responsible for taken suitable measures to remove interferences.
Causes of malfunction	<p>A maximum of reliability is ensured. Nevertheless, faults can occur during operation. These may be caused by the following, e.g.:</p> <ul style="list-style-type: none"> ● Sensor ● Process ● Voltage supply ● Signal processing
Fault rectification	The first measure to be taken is to check the output signal. In many cases, the causes can be determined this way and the faults rectified.
Checking the switching signal	<p>? SITRANS LVL200S signals "covered" when the vibrating element is not submerged (overflow protection)</p> <p>? SITRANS LVL200S signals "uncovered" when the vibrating element is submerged (dry run protection)</p> <ul style="list-style-type: none"> ● Supply voltage too low <ul style="list-style-type: none"> → Check the power supply ● Electronics defective <ul style="list-style-type: none"> → Press the mode switch (min./max.). If the instrument then changes the mode, the vibrating element may be covered with buildup or mechanically damaged. Should the switching function in the correct mode still be faulty, return the instrument for repair. → Push the mode switch. If the instrument then does not change the mode, the oscillator may be defective. Exchange the oscillator. → Check if there is buildup on the probe, and if so, remove it. ● Unfavourable installation location <ul style="list-style-type: none"> → Mount the instrument at a location in the vessel where no dead zones or air bubbles can form.

- Wrong mode selected
 - Set the correct mode on the mode switch (max.: overflow protection, min.: dry run protection). Wiring should be carried out according to the quiescent current principle.
- ? Signal lamp flashes red
 - Electronics module has detected a failure
 - Exchange instrument or return instrument for repair
- ? The signal lamp flashes alternately red and green
 - instrument defective
 - Exchange instrument or return instrument for repair

Reaction after fault rectification

Depending on the failure reason and measures taken, the steps described in chapter "Set up" must be carried out again, if necessary.

7.3 Exchange electronics

If the electronics module is defective, it can be replaced by the user.



In Ex applications only one oscillator with respective Ex approval may be used.

You find all information to the electronics exchange in the operating instructions of the new oscillator.

In general, all oscillators of series SW60 can be interchanged. If you want to use an oscillator with a different signal output, you carry out the complete setup. You find the necessary, suitable operating instruction on our homepage.



Note:

Keep in mind that enamelled instrument versions need special electronics modules. These electronics modules are called SW60E or SW60E1.

7.4 Instrument repair

If it is necessary to repair the instrument, please contact Siemens Milltronics Process Instruments Inc. You find the locations on our homepage "www.siemens.com/processautomation".

8 Dismounting

8.1 Dismounting steps

**Warning:**

Before dismounting, be aware of dangerous process conditions such as e.g. pressure in the vessel, high temperatures, corrosive or toxic products etc.

Take note of chapters "*Mounting*" and "*Connecting to power supply*" and carry out the listed steps in reverse order.



With Ex instruments, the housing cover may only be opened if there is no explosive atmosphere present.

8.2 Disposal

The instrument consists of materials which can be recycled by specialised recycling companies. We use recyclable materials and have designed the electronics to be easily separable.

WEEE directive 2002/96/EG

This instrument is not subject to the WEEE directive 2002/96/EG and the respective national laws. Pass the instrument directly on to a specialised recycling company and do not use the municipal collecting points. These may be used only for privately used products according to the WEEE directive.

Correct disposal avoids negative effects to persons and environment and ensures recycling of useful raw materials.

Materials: see chapter "*Technical data*"

If you cannot dispose of the instrument properly, please contact us about disposal methods or return.

9 Supplement

9.1 Technical data

General data

Material 316L corresponds to 1.4404 or 1.4435

Materials, wetted parts

– Process fitting - thread	316L, Hastelloy C4 (2.4602)
– Process fitting - flange	316L, 316L with Hastelloy C4 coating
– Process seal	Klingersil C-4400
– Tuning fork	316L, Hastelloy C4 (2.4610)
– Extension tube: \varnothing 21.3 mm (0.839 in)	316L, Hastelloy C4 (2.4610)

Sensor length

– Length SITRANS LVL200S	See chapter " <i>Dimensions</i> "
--------------------------	-----------------------------------

Materials, non-wetted parts

– Aluminium die-casting housing	Aluminium die-casting AlSi10Mg, powder-coated - basis: Polyester
– Stainless steel housing, electropolished	316L
– Seal between housing and housing cover	Silicone (Aluminium housing, stainless steel housing, electropolished)
– Ground terminal	316L
– Temperature adapter (optional)	316L
– Gas-tight leadthrough (optional)	316L/glass

Instrument weight (depending on process fitting)	approx. 0.8 ... 4 kg (0.18 ... 8.82 lbs)
--	--

Surface quality

– Standard	$R_a < 3 \mu\text{m}$ (1.18 ⁻⁴ in)
– Hygienic version (3A)	$R_a < 0.8 \mu\text{m}$ (3.15 ⁻⁵ in)
– Hygienic version (3A)	$R_a < 0.3 \mu\text{m}$ (1.18 ⁻⁵ in)

Process fittings

– Pipe thread, cylindrical (ISO 228 T1)	G $\frac{3}{4}$ A, G1 A
– American pipe thread, tapered	$\frac{3}{4}$ NPT or 1 NPT

– Flanges	DIN from DN 25, ANSI from 1"
– hygienic fittings	Bolting DN 40 PN 40, Tri-Clamp 1", Tri-Clamp 1½" PN 10, conus DN 25 PN 40, Tuchenha-gen Varivent DN 50 PN 10

Gas-tight leadthrough (optional)

– Leakage rate	< 10 ⁻⁶ mbar l/s
– Pressure resistance	PN 64
– hygienic fittings	Bolting DN 40 PN 40, Tri-Clamp 1", Tri-Clamp 1½" PN 10, conus DN 25 PN 40, Tuchenha-gen Varivent DN 50 PN 10

Output variable

Output	Relay output (DPDT), 2 floating spdts
Turn-on voltage	
– Min.	10 mV
– Max.	253 V AC, 253 V DC
Switching current	
– Min.	10 µA
– Max.	3 A AC, 1 A DC
Breaking capacity	
– Min.	50 mW
– Max.	750 VA AC, 54 W DC If inductive loads or stronger currents are switched through, the gold plating on the relay contact surface will be permanently damaged. The contact is then no longer suitable for switching low-level signal circuits.
Contact material (relay contacts)	AgNi or AgSnO and Au plated
Modes (adjustable)	
– A	Max. detection or overflow/overflow protection
– B	Min. detection or dry run protection

Accuracy (similar to DIN EN 60770-1)

Reference conditions and actuating variables according to DIN EN 61298-1

– Ambient temperature	+18 ... +30 °C (+64 ... +86 °F)
– Relative humidity	45 ... 75 %
– Air pressure	860 ... 1060 mbar/86 ... 106 kPa (12.5 ... 15.4 psig)

- Product temperature +18 ... +30 °C (+64 ... +86 °F)
- Product density 1 g/cm³ (0.036 lbs/in³) (water)
- Product viscosity 1 mPa s
- Superimposed pressure 0 kPa
- Sensor installation vertically from top
- Density selection switch > 0.7 g/cm³

Measuring accuracy

Deviation ± 1 mm (0.04 in)

Influence of the process temperature on the switching point

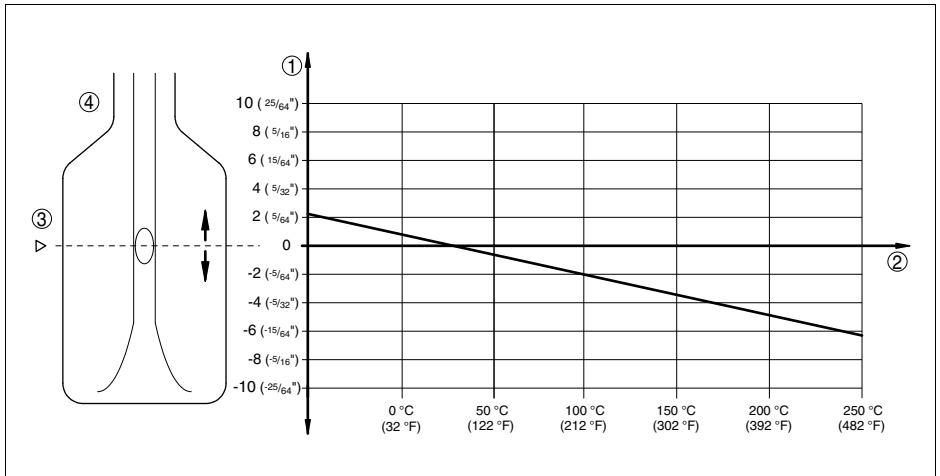

Fig. 24: Influence of the process temperature on the switching point

- 1 Shifting of the switching point in mm (in)
- 2 Process temperature in °C (°F)
- 3 Switching point at reference conditions (notch)
- 4 Tuning fork

Influence of the product density on the switching point

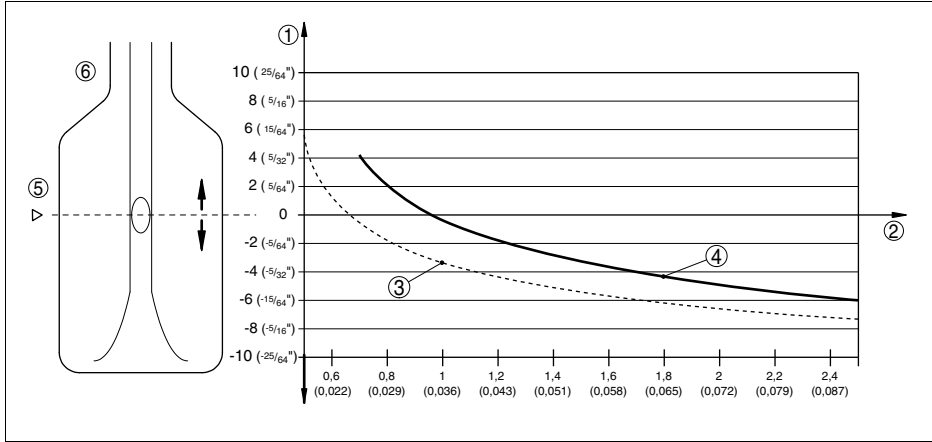

Fig. 25: Influence of the product density on the switching point

- 1 Shifting of the switching point in mm (in)
- 2 Product density in g/cm³ (lb/in³)
- 3 Switch position 0.5 g/cm³ (0.018 lb/in³)
- 4 Switch position 0.7 g/cm³ (0.025 lb/in³)
- 5 Switching point at reference conditions (notch)
- 6 Tuning fork

Influence of the process pressure to the switching point

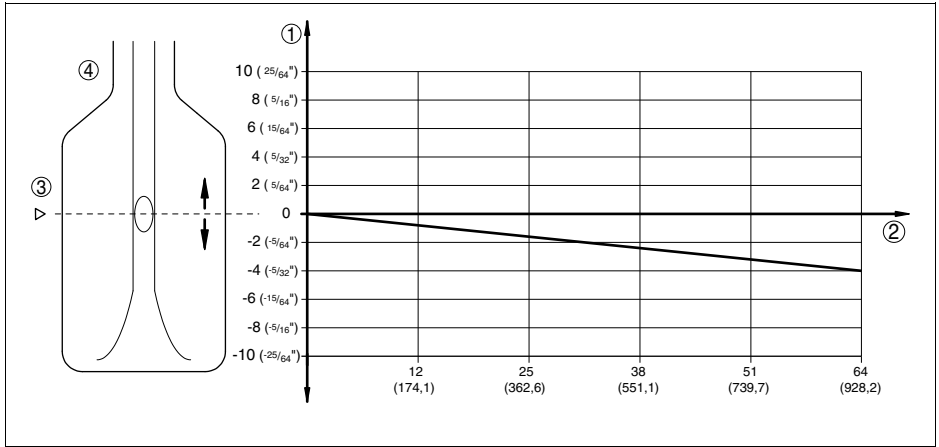

Fig. 26: Influence of the process pressure to the switching point

- 1 Shifting of the switching point in mm (in)
- 2 Process pressure in bar (psig)
- 3 Switching point at reference conditions (notch)
- 4 Tuning fork

Repeatability	0.1 mm (0.004 in)
Hysteresis	approx. 2 mm (0.08 in) with vertical installation
Switching delay	approx. 500 ms (on/off)
Frequency	approx. 1200 Hz

Ambient conditions

Ambient temperature on the housing	-40 ... +70 °C (-40 ... +158 °F)
Storage and transport temperature	-40 ... +80 °C (-40 ... +176 °F)

Process conditions

Measured value	Limit level of liquids
Process pressure	-1 ... 64 bar (-14.5 ... 928 psig) depending on the process fitting, e.g. flange (see following diagrams)
SITRANS LVL200S of 316L/Hastelloy C4 (2.4610)	-50 ... +150 °C (-58 ... +302 °F)

Process temperature (thread or flange temperature) with temperature adapter (option)

- SITRANS LVL200S of 316L/ Hastelloy C4 -50 ... +250 °C (-58 ... +482 °F)

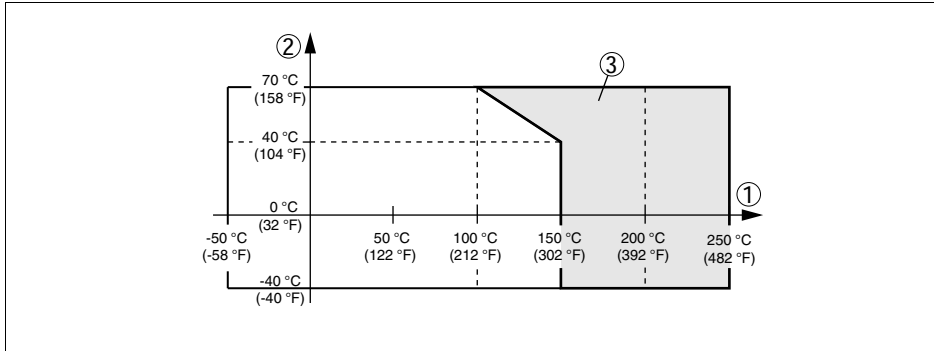

Fig. 27: Ambient temperature - Process temperature

- 1 Process temperature in °C (°F)
- 2 Ambient temperature in °C (°F)
- 3 Temperature range with temperature adapter

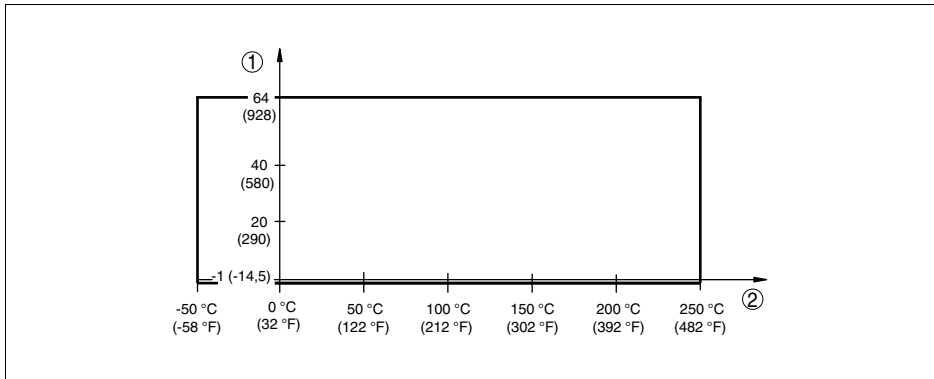

Fig. 28: Process temperature - Process pressure with switch position 0.7 g/cm³ (mode switch)

- 1 Process pressure in bar (psig)
- 2 Process temperature in °C (°F)

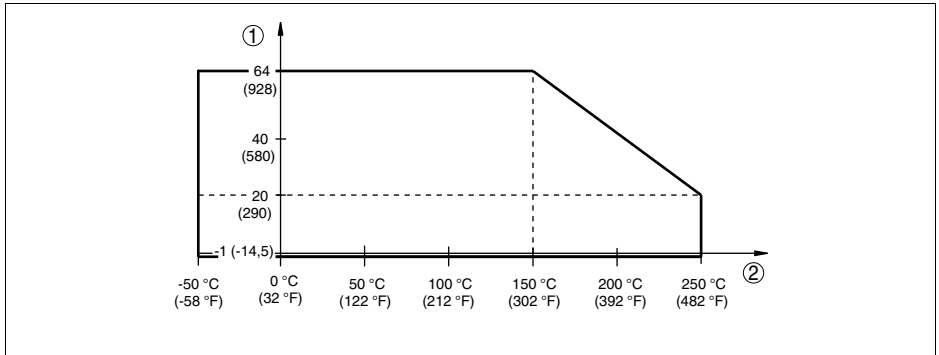

Fig. 29: Process temperature - Process pressure with switch position 0.5 g/cm³ (mode switch)

- 1 Process pressure in bar (psig)
- 2 Process temperature in °C (°F)

Viscosity - dynamic	0.1 ... 10,000 mPa s (requirement: with density 1)
Density	0.7 ... 2.5 g/cm ³ (0.025 ... 0.09 lbs/in ³); 0.5 ... 2.5 g/cm ³ (0.018 ... 0.09 lbs/in ³) by switching over

Electromechanical data

Cable entry/plug (dependent on the version)

- Single chamber housing
 - 1 x cable entry M20 x 1.5 (cable: ø 5 ... 9 mm), 1 x blind stopper M20 x 1.5; attached 1 x cable entry M20 x 1.5
 - or:
 - 1 x cable entry ½ NPT, 1 x blind stopper ½ NPT, 1 x cable entry ½ NPT
 - or:
 - 1 x plug M12 x 1; 1 x blind stopper M20 x 1.5

Screw terminals for max. wire cross-section 1.5 mm² (AWG 16)

Adjustment elements

Mode switch	
- A	Max. detection or overflow/overflow protection
- B	Min. detection or dry run protection

Density changeover switch

– 0.5	0.5 ... 2.5 g/cm ³ (0.018 ... 0.9 oz/in ³)
– 0.7	0.7 ... 2.5 g/cm ³ (0.025 ... 0.9 oz/in ³)

Voltage supply

Supply voltage	20 ... 253 V AC, 50/60 Hz, 20 ... 72 V DC (at U > 60 V DC, the ambient temperature can be max. 50 °C/122 °F)
Power consumption	1 ... 8 VA (AC), approx. 1.3 W (DC)

Electrical protective measures

Protection	IP 66/IP 67
Overvoltage category	III
Protection class	I

Approvals¹⁾

Overfill protection according to WHG (available from July 2008)

ATEX II 1G 1/2G, 2G EEx ia IIC T6

ATEX II 1/2G, 2G EEx d IIC T6²⁾

FM (NI) CL I, DIV 2, GP ABCD

FM (XP) CL I, DIV 1, GP ABCD (DIP) CL II, III, DIV 1, GP EFG³⁾

Ship approvals

¹⁾ Deviating data in Ex applications: see separate safety instructions.

²⁾ Only with Aluminium housing.

³⁾ Only with Aluminium housing.

9.2 Dimensions

SITRANS LVL200S

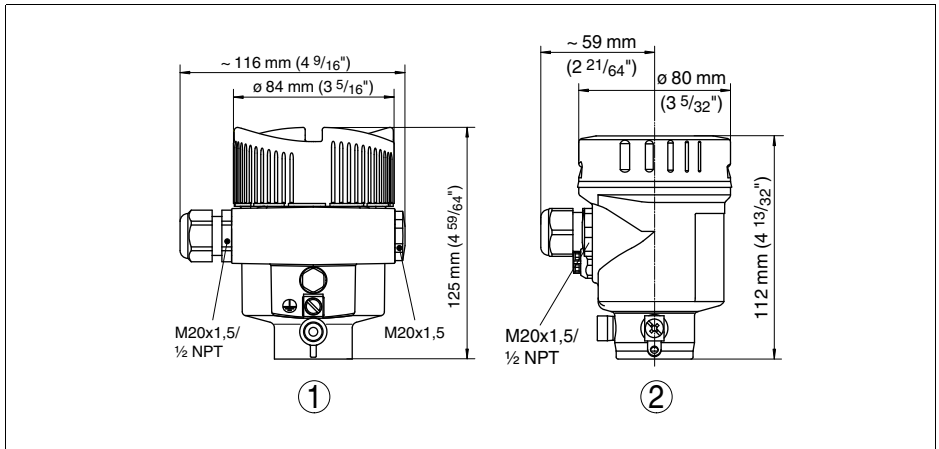

Fig. 30: Housing versions

- 1 Aluminium housing
- 2 Stainless steel housing, electropolished

SITRANS LVL200S

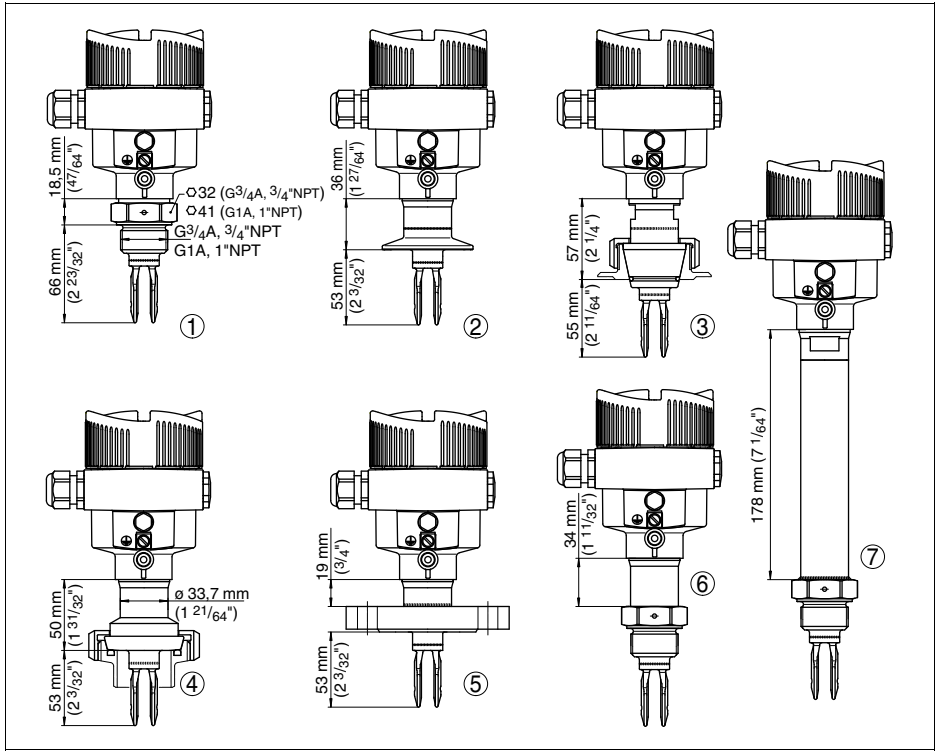

Fig. 31: SITRANS LVL200S

- 1 Thread
- 2 Tri-Clamp
- 3 Cone DN 25
- 4 Bolting DN 40
- 5 Flange
- 6 Gas-tight leadthrough
- 7 Temperature adapter



www.siemens.com/processautomation

Siemens Milltronics Process Instruments Inc.
1954 Technology Drive, P.O. Box 4225
Peterborough, ON, Canada K9J 7B1
Tel: (705) 745-2431 Fax: (705) 741-0466
Email: techpubs.smpi@siemens.com

© Siemens Milltronics Process Instruments Inc. 2008
Subject to change without prior notice



7 M L 1 9 9 8 5 K R 0 1

Rev. 1.0

33836-EN-080421